



# DYNAMAX™ SPEAKERS



## Sleek Design Meets High-Performance

The Dynamax, ES100, speaker features the Federal Signal Neo driver for increased performance and reliability. The larger diaphragm of the ES100 allows the speaker to capture lower frequency ranges for a more robust sound.

The ES100 is a 100-watt speaker designed to withstand the toughest conditions. The Dynamax is made of black corrosion resistant aluminum housing and is fully encapsulated.

Designed for versatility, the ES100 mounts easily into grille, flush between the bumper and hose tray of large apparatus and to most vehicle bumpers. A variety of mounts and brackets are also available to make installation as simple as possible.



*DynaMax speakers fit easily behind the grille.*

## > Features

- Neo driver.
- 100-watt power.
- Slim and lightweight.
- Easy to install and maintain.
- Can be used on large apparatus, ambulances, law enforcement vehicles, and command fleet.
- Durable and reliable.

## > Approval

- SAE and CCR specifications when paired with Class A Federal Signal amplifier and electronic siren.

## > How to Order

### Select Model

**ES100** Speaker, 100-watt, high output compact

### Brackets

- ESB-U** Universal bail bracket, all vehicles
- ESB-V97** Ford Crown Vic Interceptor, '97
- ESB-V01** Ford Crown Vic, Interceptor, '98-'01
- ESB-V08** Ford Crown Vic, Interceptor, '02-'08
- ESB-TAH02** Chevrolet Tahoe, '02 & earlier
- ESB-TAH05** Chevrolet Tahoe, '03-'05 Police only
- ESB-TAH08** Chevrolet Tahoe, '03-'08
- ESB-IMP02** Chevrolet, Impala, '00-'02 police, '04 civilian
- ESB-IMP08** Chevrolet, Impala, '06-'08
- ESB-CRG07** Dodge Charger, '07
- ESB-HMR** Hummer H3, '07
- ESB-EXP07** Ford Explorer, '07
- ESB-EXP05** Ford Explorer/Expedition, '95-'05
- ESBMT-SB** Bumper/surface mount bracket
- ESFMT** Recess mount, polished trim ring
- ESFMT-EF** Recess mount, stainless steel "Electric F" grille



Flush mount, *ESFMT*



Flush mount with grille, *ESFMT-EF*



Bumper mount, *ESBMT*

Factory Set Specifications	
Input Voltage	32VRMS
Power	100W
Sound Output	SAE J1849 CCR Title 13
Impedance	11 ohms
Physical Dimensions	
Height	5.5 in (14 cm)
Width	5.9 in (15 cm)
Depth	2.7 in (6.9 cm)
Ship Weight	
	5.5 lbs (2.5 kg)

### Dimensional Diagrams

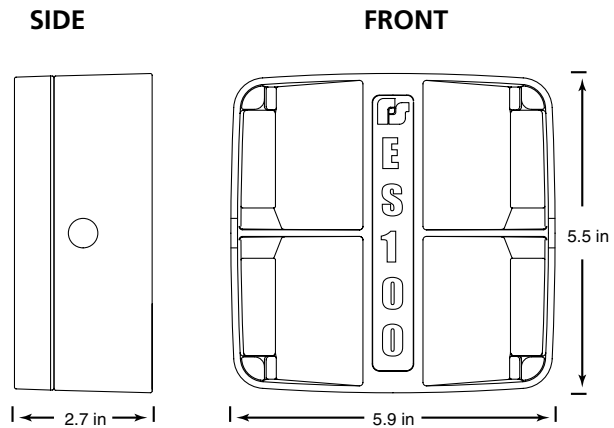

**FEDERAL SIGNAL**

2645 Federal Signal Drive, University Park, IL 60466-3195  
 Tel.: (800) 264-3578 • Fax: (800) 682-8022  
 www.fedsig.com

Warning: Sirens and Speakers may produce LOUD sounds necessary to request the right-of-way. Sirens and Speakers may cause hearing damage. Wear hearing protection.

DynaMax is a trademark of Federal Signal Corporation.

©2009 Federal Signal Corporation. M2516 | 609