



# VIPER™ S2 INTERNAL LED WARNING LIGHTS

available in:



The Federal Signal Viper™ S2 with superior light output and easy pattern synchronization advances lighting expectations to a higher plateau. Exceptional warning capability, multiple model configurations, versatile mounting and simple product functionality make the Viper S2 stand out as the best internal warning light in the industry.

## Advanced Solaris Reflective Light Output

Bold blocks of light and superior off-axis reflection are achieved using advanced Solaris™ reflector technology. Molded scalloped facets at the rear of the reflector direct LED light forward to form an impressive block of illumination. Two inboard side reflectors mirror high intensity LED light to the side producing wide-angle off-axis warning.

## Easy Push Button Pattern Selection and Multi-Head Synchronization

Viper S2 lights are available in single- or dual-head configurations. Both styles are available with a cigarette plug, as a stand-alone type, or synchronized. Stand-alone units work independently and have up to 23-patterns that are selected by an easy to reach push button switch. Synchronized units use an advanced two-phase wire technology that coordinates flash patterns between up to eight lights at once. Synchronized light patterns can be set to work as either concurrent flash or opposite flash. The simple to use, multi-purpose push-button pattern switch is used to scroll forward and backward through patterns and also to synchronize the light heads.

## Stylish Built-In Versatility

Viper S2 lights deliver dramatic light output and can be mounted almost anywhere inside the emergency vehicle. The housing is compact and made of lightweight polycarbonate which is safer in case of accident or air bag deployment. Mounting the Viper S2 is made quick and versatile with a swivel type bail bracket and suction cups. Each unit comes equipped with a snap-on flash guard (no screws required) and reflective tape to help optimize forward LED light output. All models are shipped complete with flash guard, reflective tape, bracket and mounting hardware. Wire harness lengths are five feet long with synchronized units and nine feet long with cigarette plug units.

## > Features

- Advanced Solaris™ LED reflective light technology.
- Stylish single-and-dual head models.
- Functional push button synchronization and pattern control.
- Choice of cigarette plug and synchronized models.
- New/innovative built-in warning patterns.
- Full variety of high intensity LED colors to choose from.
- Versatile mounting brackets and snap-on flash guards included.
- Extremely low amp draw.
- Quietly meets EMI and RFI requirements.



## > How to Order

### Select model

- 329000-X** Single head (8 LEDs), 23 patterns, cigarette plug
- 329001-X** Single head (8 LEDs), 23 patterns, 2P Sync
- 329000-XX** Dual head (16 LEDs), 25 patterns, cigarette plug
- 329001-XX** Dual head (16 LEDs), 25 patterns, 2P Sync

2 = Amber, 3 = Blue, 4 = Red, 5 = White

Example: 329001-34 = dual head, driver side blue and passenger side red with 2 phase synchronization

### Select a Mounting Bracket (optional)

- 350701-01** Bracket, Viper S2, dual-head, mounts right above rear deck brake light, late model Ford Crown Victoria Police Interceptor vehicles
- 350701-02** Bracket, Viper S2, dual head, rear view mirror/headliner mount, late model Ford Crown Victoria Police Interceptor vehicles.
- 350701-03** Bracket, Viper S2, dual head, rear view mirror/headliner mount, late model Ford Crown Victoria Police Interceptor vehicles

	Single Unit	Dual Unit
<b>Specifications</b>		
Volts	12.8 VDC	
Current Draw	1.5A	2.2A
Operating Temp	-30°C to +65°C	
<b>Physical Dimensions</b>		
Width	4.3 in (10.9 cm)	8.5 in (21.6 cm)
Height	1.2 in (3.0 cm)	1.2 in (3.0 cm)
Depth	2.9 in (7.4 cm)	2.9 in (7.4 cm)
<b>Ship Weight</b>		
	1.0 lb (.45 kg)	1.5 lbs (.68 kg)



### Patterns

Single Units		Dual Units	
1	Null	1	Null
2	79 FPM Power Quad	2	Alternating 150 FPM Single
3	150 FPM Single	3	Alternating 240 FPM Single
4	151 FPM Single	4	Alternating 75 FPM Single
5	74 FPM Single	5	Alternating 150 FPM Triple
6	75 FPM Single	6	Alternating 75 FPM Triple
7	240 FPM Single	7	Precise Flip-Flop 63 FPM
8	241 FPM Single	8	Overlap 71 FPM Quad
9	240 FPM Double	9	Alt. Overlap 50 FPM Power Quad
10	241 FPM Double	10	Alt. Overlap 40 FPM Power Quad
11	150 FPM Double	11	Alt. Overlap 100 FPM Double
12	151 FPM Double	12	Alternating Progressive
13	74 FPM Double	13	Alt. 2 Quad. @ 70 FPM 4 Single @150 FPM
14	75 FPM Double	14	Alt. 5 Single @ 320 FPM 1 Power Quint @ 90 FPM
15	150 FPM Triple	15	Alt. 2 Quad @ 83 FPM 4 Single @ 272 FPM
16	75 FPM Triple	16	Overlap 3 Single @180 FPM 4 Single @ 706 FPM 3 Single @ 390 FPM 6 Single @ 660 FPM
17	5 Single @ 680 FPM 4 Single @ 216 FPM	17	Overlap Power Quad 75 FPM
18	4 Single @ 570 FPM 3 Single @ 246 FPM	18	Random
19	3 Single @ 460 FPM 2 Quad @ 75 FPM	19	Steady/166 FPM Single
20	Progressive	20	Steady/103 FPM Burst
21	4 Single @154 FPM 2 Quad @ 75 FPM	21	Steady/4 Single @ 700 FPM 2 Single @ 230 FPM
22	Random	22	166 FPM Single/Steady
23	Steady Burn	23	103 FPM Burst/Steady
		24	4 Single @ 700 FPM/Steady 2 Single @ 720 FPM/Steady
		25	Steady Burn

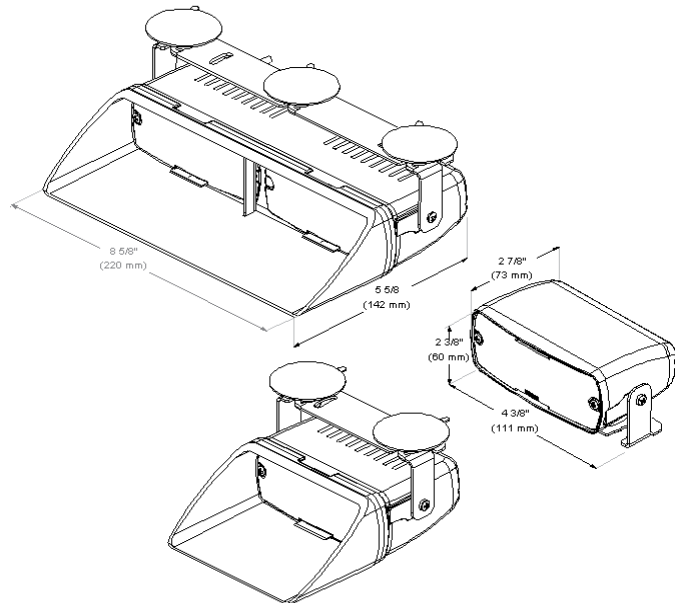

**FEDERAL SIGNAL**

2645 Federal Signal Drive, University Park, IL 60484  
Tel.: (800) 264-3578 • Fax: (800) 682-8022  
www.fedsig.com

Viper S2 and Solaris are trademarks of Federal Signal Corporation.

©2012 Federal Signal Corporation. M3530 I 312